

EUSD - EUSDx

UNINSULATED TYPE
BULKHEAD FOCUS



Cruise Ship



Yatch



Navy



FPSO



Oil & Gas



FIRE – FIRE & GAS DAMPER

Introduction

Europair dampers are used in HVAC and ventilation systems to prevent or stop the spread of flames or smoke between divisions of the fire zone.

Marine and Off-shore divisions are classified H, A and B depending on scope and divisions type.

The different divisions are insulated according to the parameters defined by SOLAS; dampers are components installed in duct between the zone divisions and have to respect the structure fire rate.

Application

Europair EUSD “uninsulated” dampers, have been tested and certified for the installation in Class “A” bulkhead.

Class “A” is the most common used rate in Marine and Off-shore applications.

EUSD fire dampers rated Class “A” can be installed in “A0” or “A60” structures.

For “A0” Class, dampers have to pass 1 hour fire test without any structural failure.

For “A60” Class, dampers have to maintain division integrity and resist the flame passage at least for 60

minutes; during this period, the thermocouples placed on unexposed side of the coaming (25 mm from the bulkhead and 25 mm from the end of coaming) have to arrive at a temperature no more than 180°C.

Testing, Approvals, Conformities

EUSD damper: A0 – A30 – A60 Class “uninsulated” fire damper for bulkhead installation (in galvanised steel)

EUSDX damper: A0 – A30 Class “uninsulated” fire damper for bulkhead installation (AISI 316L)

EUSD damper: A0 – A15 Class “uninsulated” fire damper for deck installation (in galvanized steel)

MED Marine Equipment Directive: DNV MEDB00007XD

Type Approval Certificate: DNV TAF00001NZ

Module D: DNV MEDD00002AF

USCG: DNV 164.139/EC0575/MEDB00007XD

Shock Test MIL-S-901 D: 1989: Cetena nr. 371/2021

ATEX Directive 2014/34/EU: TUV Nord nr. TUV IT 12 ATEX 026 Rev. 3

Leakage test EN 1751 Class 2/B (Class 3/C on demand)



Certificates



FIRE TEST ACCORDING TO SOLAS



Initial stage of the test



Final stage of the test

SHOCK TEST ACCORDING TO MIL-S-901 D: 1989



Horizontal position



30° inclined



30° inclined and rotated

EUSD – EUSDx Solas Fire Damper

Technical Information

Minimum size: 100 x 100 x 150 mm

Maximum size: 1000 x 1150 x 150 mm

Material of Construction

Galvanised sheet steel Z200 (Z275 on demand)

AISI 316L

Casing and flanges:

- Clinched corners
- Casing fixed with structural rivets
- Flanges and drilling ISO 15138 (customized on demand)
- Casing thickness 2,0 mm: depth 150 mm (200 mm, 300 mm on demand)

Blades:

- Thickness 1,5 + 1,5 mm double skin
- Fixed on shaft with structural rivets and welded points

Shaft:

- DN 18 mm with square terminal

Bearings:

- Sintered bronze bearings
- Work operation up to -55°C

Side seal:

- AISI 301

Linkages:

- Galvanized Z200 or AISI 316
- Thickness 3,0 mm

Gasket / Seal:

- Option for leakage Class 3
- Mineral fibre seal
- Non-combustible approved by RINA with MED certification

Earthing system:

- Earthing boss or earthing bolt and nuts for Atex execution

Lifting lugs:

- On demand

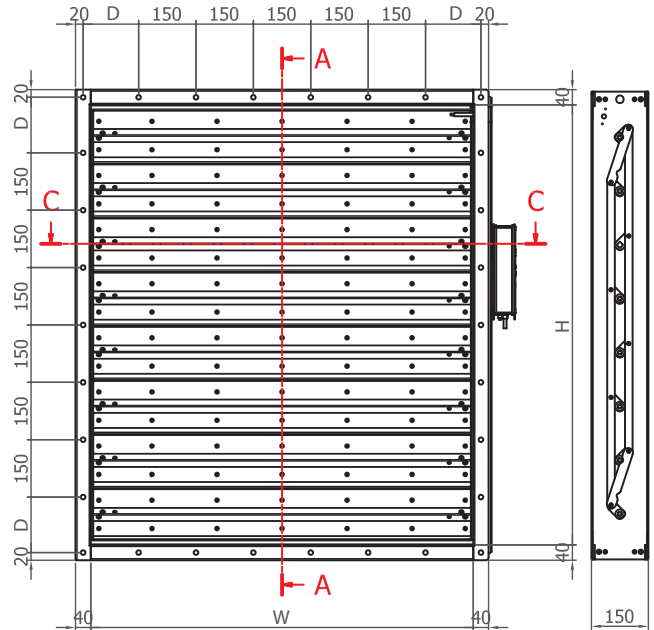

Drilling ISO 15138 Rectangular Ductwork

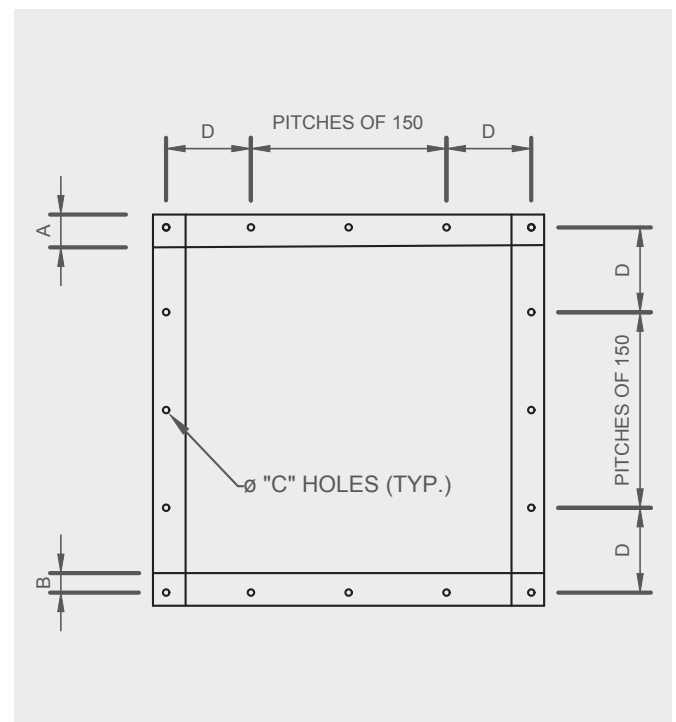

Notes:

Dimension "D" is to be a minimum of 75 mm or a maximum of 150 mm.

Inside Duct Size (Rectangular)	"A"	"B"	"C"	Bolt Size
Up to 350 mm Longest Side	40	20	10	M8
351 to 1000 mm Longest Side	50	30	12	M10
Over 1000 mm Longest Side	80	40	14	M12

Technical Data

PRESSURE LOSS AND SOUND POWER LEVEL		
V	0°	
	Δp_t	LwA
1	< 5	< 20
2	< 5	23
3	< 5	34
4	< 5	42
5	< 5	48
6	< 5	53
7	7	57
8	9	61
9	11	64
10	13	68
11	16	71
12	19	73
13	22	75
14	25	77
15	27	79

- V:** velocity on WxH [m/s]
 Δp_t : pressure drop [Pa]
LwA: sound power level [dB(A)]
 α° : (0° damper fully open)

Installation Type 1/A (BULKHEAD) for EUSD A60 - EUSDX A30

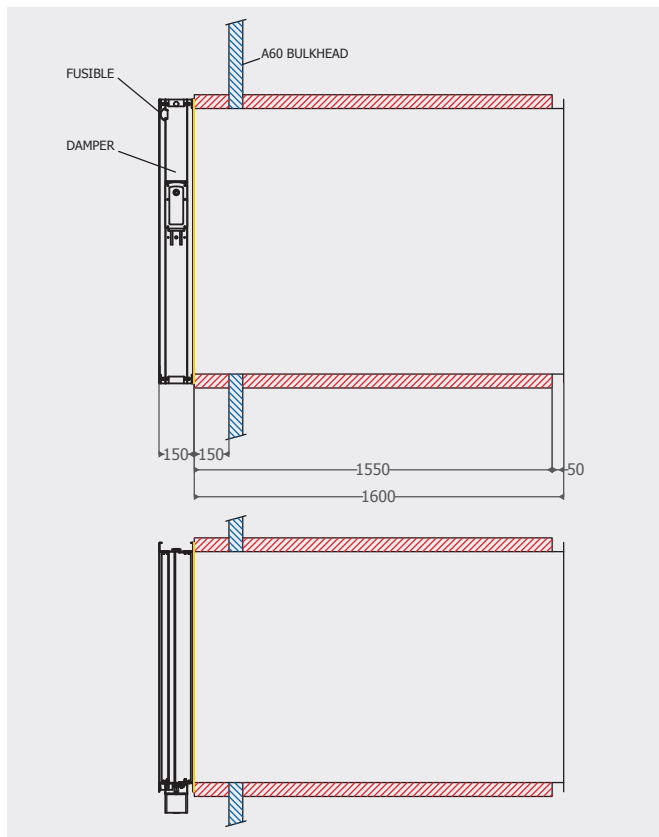

- SEA ROX SL 620; 60 mm; 100 kg/m³
- A 60 BULKHEAD INSULATION
- MINERAL FIBRE SEALANT 40x3 mm
NON COMBUSTIBLE RINA MED321615 CS

DAMPER WEIGHT

Casing 2.0 mm /150

H/W	100	200	300	400	500	600	700	800	900	1000
100	3,0	4,5	6,0	7,5	9,0	10,5	12,0	13,5	15,0	16,5
200	4,5	6,5	8,5	10,5	12,5	14,5	16,5	18,5	20,5	22,5
300	6,0	8,0	10,5	12,5	14,5	17,0	19,0	21,5	23,5	26,0
400	7,5	10,0	13,0	15,5	18,0	21,0	23,5	26,5	29,0	32,0
500	9,0	12,0	15,5	18,5	22,0	25,0	28,5	31,5	35,0	38,0
600	10,0	13,5	17,0	20,5	24,0	27,5	31,0	34,5	38,0	41,5
700	11,5	15,5	19,5	23,5	27,5	31,5	35,5	39,5	43,5	47,5
800	13,0	17,5	22,0	26,5	31,0	35,5	40,0	44,5	49,0	53,5
900	14,0	19,0	23,5	28,5	33,0	38,0	42,5	47,5	52,0	57,0
1000	15,5	21,0	26,0	31,0	36,5	41,5	47,0	52,0	57,5	62,5
1100	17,0	23,0	29,0	34,5	40,5	46,0	52,0	58,0	63,5	69,5
1150	17,5	23,5	29,0	35,0	41,0	46,5	52,5	58,5	64,0	70,0

NOTE:

The weight of the actuator must be added to the weight of the damper

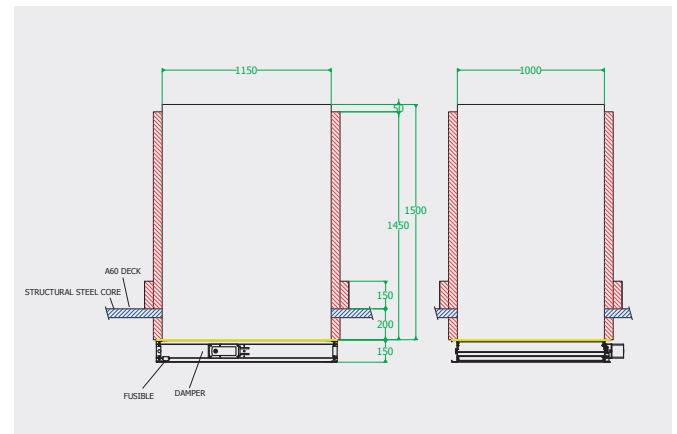

Installation Type 1/B (DECK) for EUSD A15





- SEA ROX SL 620; 60 mm; 100 kg/m³
- A 60 DECK INSULATION
- MINERAL FIBRE SEALANT 30x3 mm
NON COMBUSTIBLE RINA MED321615 CS

CONTROLS

Electric actuators for safe area BELIMO

	TYPE	Open / Close Nm	V	Thermal trigger 72° C	Weight Kg
	BFL24-T	4 Nm/ 3 Nm	24 V AC/DC	BAT	1.1
	BFL230-T	4 Nm/ 3 Nm	230 V AC	BAT	1.1
	BFN24-T	9 Nm/ 7 Nm	24 V AC/DC	BAT	1.4
	BFN230-T	9 Nm/ 7 Nm	230 V AC	BAT	1.4
	BF24-TN	18 Nm/ 12 Nm	24 V AC/DC	BAE	2.7
	BF230-TN	18 Nm/ 12 Nm	230 V AC	BAE	2.7
	BF24-C232	20 Nm/ 20 Nm	24 V AC/DC	BAE	2.7
	BF230-C232	20 Nm/ 20 Nm	230 V AC	BAE	2.7

Electric actuators for safe / hazardous area SCHISCHEK

	TYPE	Open / Close Nm	V	Thermal trigger 72° C	Weight Kg
	InMax 5.10 BF	5 or 10 Nm	24 - 240 V AC/DC	InPro-TT	1.1
	InMax 15 BF	15 Nm	24 - 240 V AC/DC	InPro-TT	1.1
	InMax 8 BF1	8 Nm	24 - 240 V AC/DC	InPro-TT	1.1
	InMax 15BF1	15 Nm	24 - 240 V AC/DC	InPro-TT	1.1
ZONE 2/22 	RedMax 5.10 BF	5 or 10 Nm	24 - 240 V AC/DC	ExPro-TT	3.5
	RedMax 15 BF	15 Nm	24 - 240 V AC/DC	ExPro-TT	3.5
	RedMax 8 BF1	8 Nm	24 - 240 V AC/DC	ExPro-TT	3.5
	RedMax 15BF1	15 Nm	24 - 240 V AC/DC	ExPro-TT	3.5
ZONE 1/21 	ExMax 5.10 BF	5 or 10 Nm	24 - 240 V AC/DC	ExPro-TT	3.5
	ExMax 15 BF	15 Nm	24 - 240 V AC/DC	ExPro-TT	3.5
	ExMax 8 BF1	8 Nm	24 - 240 V AC/DC	ExPro-TT	3.5
	ExMax 15BF1	15 Nm	24 - 240 V AC/DC	ExPro-TT	3.5

Options:

CTS Seawater resisting paint, cable glands nickel plated

VAS Stainless Steel casing, cable glands nickel plated
(add 7,0 kg to the actuator weight)

... S3 ambient temperature up to +60°C; 110...240 V AC

NOTE:

all actuators are provided with integrated limit switches

ACCESSORIES

Control Unit

This unit is designed to control and monitor the electrical operated Fire Dampers.

The control unit could be used to provide local manual damper control from each side of the division as per Solas indications.

SAFE AREA (type MPY125)

Junction box in Polycarbonate UL94-V0;

IP 44 or IP 66 (on demand)

Internal electric card

Selection knob on external cover

Terminal block

Position indicator led

Lamp test

Transparent pocket for damper TAG

Cable gland PG21 in polyamide

Voltage 24 ÷ 230V AC; 18 ÷ 28 V DC



HAZARDOUS AREA (type ATEX)

Junction box in aluminum copper free

II 2G Ex db IIB+H2 T5 Gb / II 2D Ex tb IIIC T100°C Db IP66

Internal electric card

Selection knob on external cover

Terminal block

Position indicator led

Lamp test

Cable gland M25 in Nickel Plated

Voltage 24 ÷ 230V AC; 18 ÷ 28V DC



JUNCTION BOX “MARINE”

This junction box is necessary to wire the Fire damper to Control Units, AHU and ESD (Emergency Shutdown System).

The innovative design of the internal electric board, permits to communicate the damper status to ESD System “without” the additional switches; this means a *cost saving* in components and wiring.

In addition, each cable gland is exactly located in the direction of the right connector that it is also identified with a TAG; this is to avoid any wiring error.

Junction box in Polystyrene

IP 56

Internal electric card

Terminal block

Cable glands PG11 in polyamide for actuator and switches entries (2)

Cable glands PG21 In polyamide for Control units entries (2) and for AHU wiring (1)

Voltage 24 ÷ 230V AC; 18 ÷ 28V DC

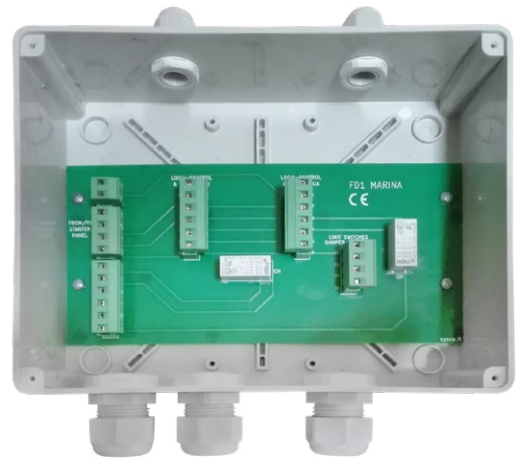

TYPICAL WIRING

FROM / TO AHU - ESD SHIP CONTROL

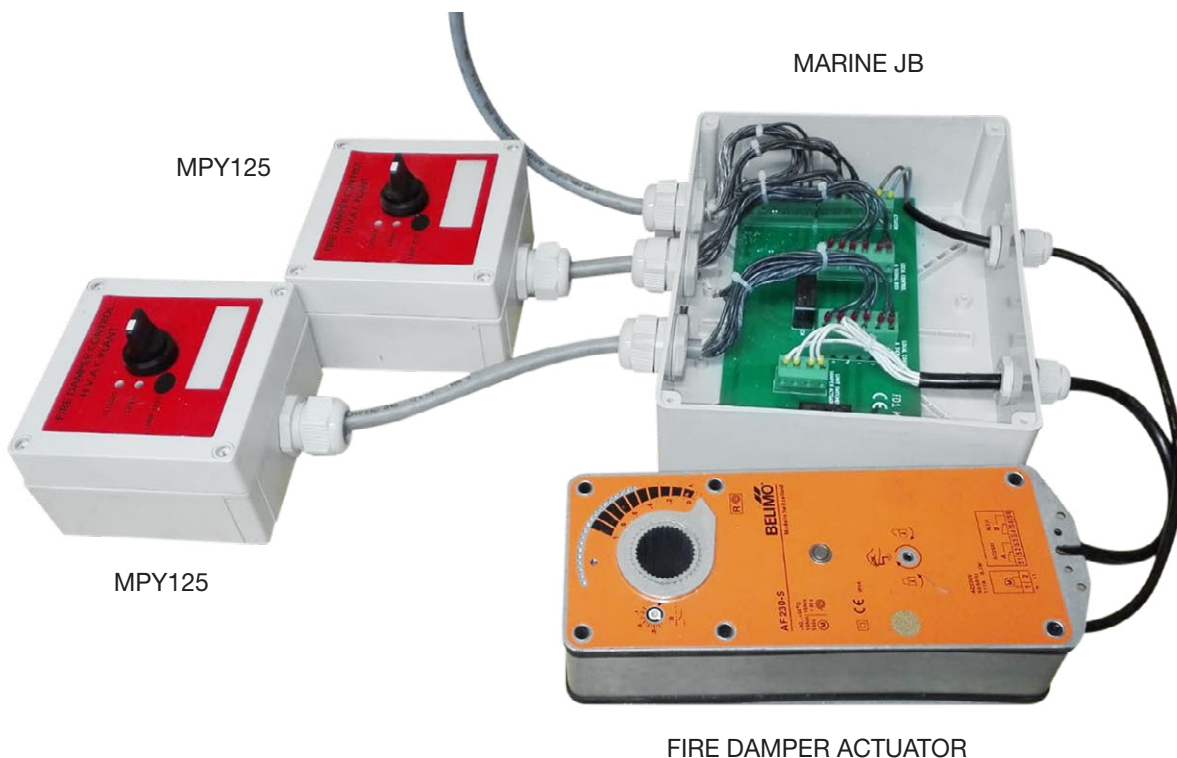

MARINE JB FUNCTIONS AND WIRING

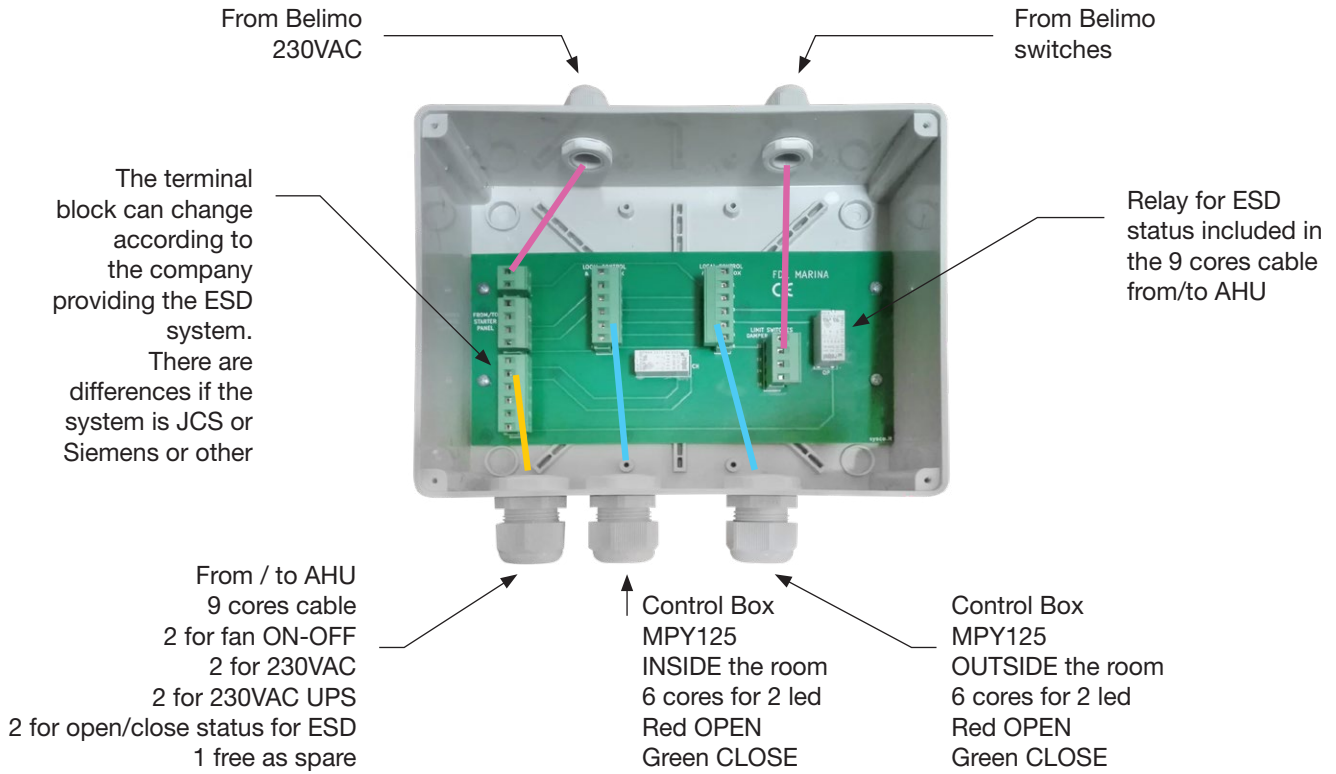

WIRING DIAGRAM FOR CONTROL BOX 2 LED RED OPEN - GREEN CLOSE

1: N Belimo
A: L1 Belimo

S1: S1 Belimo
S2: S2 Belimo
S4: S4 Belimo
S6: S6 Belimo

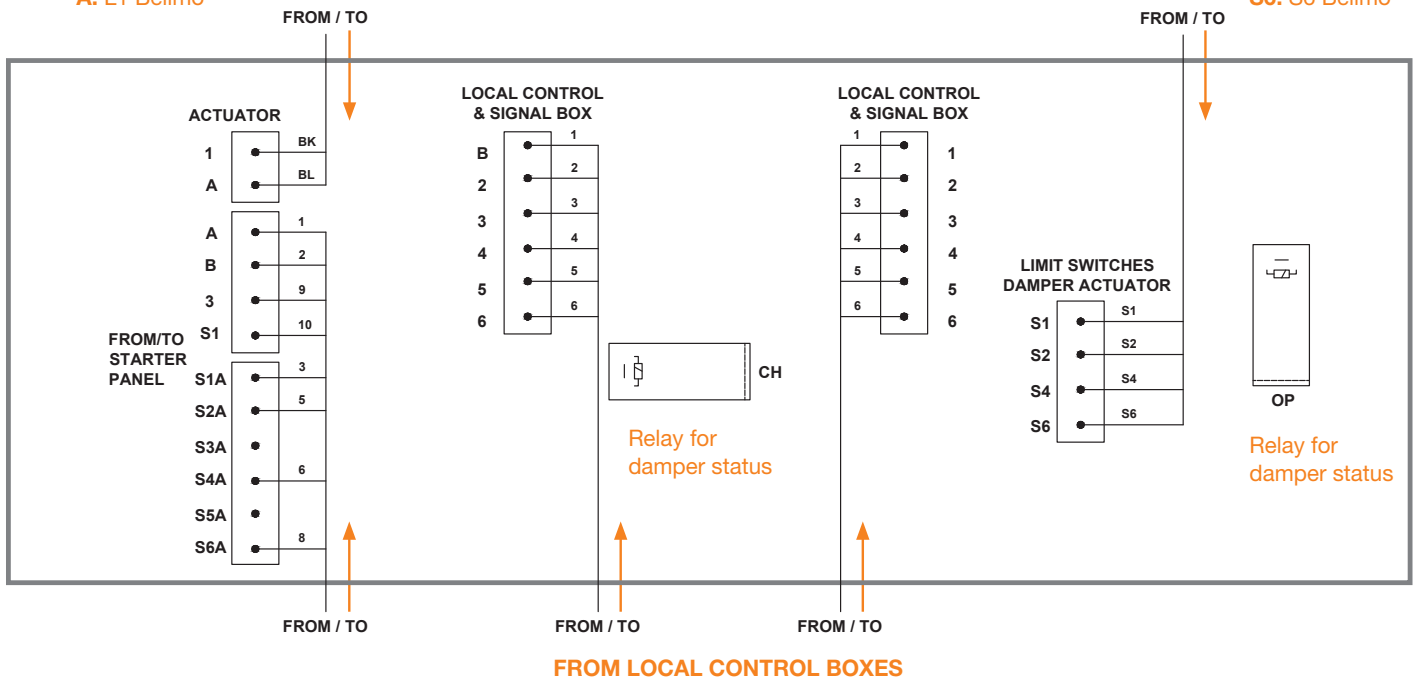

FROM AHU

A/B: 230V actuator electrical power
3/S1: UPS electrical power for LED
S1A/S2A: damper status for ESD Ship system
S4A/S6A: fan start



Fire - Fire & Gas Damper EUSD - EUSDx

Cruise Ship

Yatch

Navy

FPSO

Oil & Gas

Europair s.r.l.

Via Po, 160

20032 Cormano (MI)

Tel. 02.66305530

info@europairitalia.it

commerciale@europairitalia.it